



US009723687B2

(12) **United States Patent**
Kim

(10) **Patent No.:** **US 9,723,687 B2**
(45) **Date of Patent:** ***Aug. 1, 2017**

(54) **ORGANIC EL DISPLAY PANEL FOR REDUCING RESISTANCE OF ELECTRODE LINES**

(58) **Field of Classification Search**
CPC H05B 33/06; H05B 33/22; H05B 33/28; H05B 33/145; H05B 33/26; H05B 33/10;
(Continued)

(71) Applicant: **Microsoft Technology Licensing, LLC**, Redmond, WA (US)

(56) **References Cited**

(72) Inventor: **Chang Nam Kim**, Seoul (KR)

U.S. PATENT DOCUMENTS

(73) Assignee: **MICROSOFT TECHNOLOGY LICENSING, LLC**, Redmond, WA (US)

4,266,223 A 5/1981 Frame
4,720,432 A 1/1988 VanSlyke et al.
(Continued)

(*) Notice: Subject to any disclaimer, the term of this patent is extended or adjusted under 35 U.S.C. 154(b) by 0 days.

This patent is subject to a terminal disclaimer.

FOREIGN PATENT DOCUMENTS

EP 0966182 A1 12/1999
EP 1022931 A1 7/2000
(Continued)

(21) Appl. No.: **14/959,624**

OTHER PUBLICATIONS

(22) Filed: **Dec. 4, 2015**

United States Patent and Trademark Office, Office Action Issued in U.S. Appl. No. 12/362,138, Dec. 22, 2010, 12 pages.

(Continued)

(65) **Prior Publication Data**
US 2016/0120006 A1 Apr. 28, 2016

Primary Examiner — Anh Mai
Assistant Examiner — Nathaniel Lee
(74) *Attorney, Agent, or Firm* — Alleman Hall Creasman & Tuttle LLP

Related U.S. Application Data

(63) Continuation of application No. 11/703,251, filed on Feb. 7, 2007, now Pat. No. 9,237,629, which is a (Continued)

(30) **Foreign Application Priority Data**

Sep. 5, 2002 (KR) 2002-0053562

(57) **ABSTRACT**

(51) **Int. Cl.**
H05B 33/26 (2006.01)
H01L 51/52 (2006.01)
(Continued)

Method for fabricating an organic EL display panel having an EL region at every cross of first and second electrodes, including the steps of forming a plurality of first electrodes at regular intervals on a transparent substrate, forming an insulating later in regions other than the EL regions, forming second supplementary electrodes on the insulating layer, forming an electric insulating barrier between adjacent EL regions perpendicular to the first electrodes, forming an organic EL layer in each of the EL regions with a shadow mask, depositing an electrode material on an entire surface inclusive of the organic EL layer, to form a plurality of second electrodes, and forming a protection film on an entire surface inclusive of the second electrodes.

(52) **U.S. Cl.**
CPC **H05B 33/26** (2013.01); **H01L 51/5206** (2013.01); **H01L 51/5212** (2013.01);
(Continued)

20 Claims, 11 Drawing Sheets

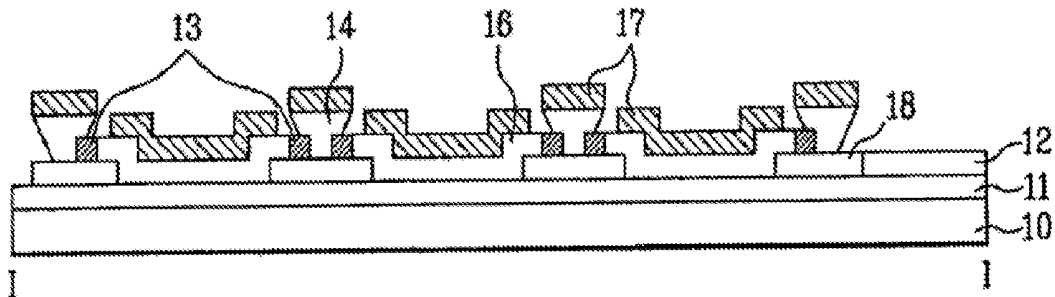

Related U.S. Application Data

continuation of application No. 10/654,896, filed on Sep. 5, 2003, now Pat. No. 7,211,947.

JP	2000331783 A	11/2000
JP	2001185363 A	7/2001
WO	0163975 A1	8/2001

OTHER PUBLICATIONS

- (51) **Int. Cl.**
H05B 33/10 (2006.01)
H05B 33/06 (2006.01)
H05B 33/14 (2006.01)
H01L 27/32 (2006.01)
- (52) **U.S. Cl.**
 CPC *H01L 51/5221* (2013.01); *H05B 33/06* (2013.01); *H05B 33/10* (2013.01); *H05B 33/14* (2013.01); *H01L 27/3211* (2013.01); *H01L 27/3281* (2013.01)
- (58) **Field of Classification Search**
 CPC . *H05B 33/14*; *H01L 27/3246*; *H01L 27/3281*; *H01L 27/3283*; *H01L 27/3295*; *H01L 51/5203*; *H01L 51/5284*; *H01L 51/5206*; *H01L 51/5212*; *H01L 51/5221*; F21Y 2105/001
 USPC 313/498–512
 See application file for complete search history.

United States Patent and Trademark Office, Office Action Issued in U.S. Appl. No. 12/362,138, Jun. 8, 2011, 19 pages.
 United States Patent and Trademark Office, Office Action Issued in U.S. Appl. No. 12/362,138, Mar. 26, 2012, 8 pages.
 United States Patent and Trademark Office, Office Action Issued in U.S. Appl. No. 12/362,138, Oct. 22, 2012, 9 pages.
 United States Patent and Trademark Office, Office Action Issued in U.S. Appl. No. 10/654,896, Jan. 11, 2006, 6 pages.
 United States Patent and Trademark Office, Office Action Issued in U.S. Appl. No. 10/654,896, Jun. 30, 2006, 7 pages.
 United States Patent and Trademark Office, Office Action Issued in U.S. Appl. No. 10/654,896, Oct. 3, 2006, 6 pages.
 United States Patent and Trademark Office, Notice of Allowance Issued in U.S. Appl. No. 10/654,896, Nov. 2, 2006, 7 pages.
 United States Patent and Trademark Office, Office Action Issued in U.S. Appl. No. 11/703,251, Jul. 22, 2009, 12 pages.
 United States Patent and Trademark Office, Office Action Issued in U.S. Appl. No. 11/703,251, Jan. 14, 2010, 11 pages.
 United States Patent and Trademark Office, Office Action Issued in U.S. Appl. No. 11/703,251, Jun. 3, 2010, 14 pages.
 United States Patent and Trademark Office, Office Action Issued in U.S. Appl. No. 11/703,251, Nov. 2, 2010, 10 pages.
 United States Patent and Trademark Office, Office Action Issued in U.S. Appl. No. 11/703,251, Mar. 29, 2011, 14 pages.
 United States Patent and Trademark Office, Office Action Issued in U.S. Appl. No. 11/703,251, Oct. 21, 2011, 18 pages.
 United States Patent and Trademark Office, Office Action Issued in U.S. Appl. No. 11/703,251, Mar. 27, 2012, 11 pages.
 United States Patent and Trademark Office, Office Action Issued in U.S. Appl. No. 11/703,251, Sep. 6, 2012, 14 pages.
 United States Patent and Trademark Office, Office Action Issued in U.S. Appl. No. 11/703,251, Jan. 15, 2013, 11 pages.
 United States Patent and Trademark Office, Notice of Allowance Issued in U.S. Appl. No. 12/362,138, Jan. 17, 2013, 9 pages.
 United States Patent and Trademark Office, Office Action Issued in U.S. Appl. No. 11/703,251, Jun. 14, 2013, 12 pages.
 United States Patent and Trademark Office, Office Action Issued in U.S. Appl. No. 11/703,251, Nov. 25, 2013, 12 pages.
 United States Patent and Trademark Office, Office Action Issued in U.S. Appl. No. 11/703,251, Mar. 11, 2014, 13 pages.
 United States Patent and Trademark Office, Office Action Issued in U.S. Appl. No. 11/703,251, May 22, 2014, 14 pages.
 United States Patent and Trademark Office, Office Action Issued in U.S. Appl. No. 11/703,251, Nov. 6, 2014, 13 pages.
 United States Patent and Trademark Office, Office Action Issued in U.S. Appl. No. 11/703,251, Feb. 12, 2015, 13 pages.
 United States Patent and Trademark Office, Notice of Allowance Issued in U.S. Appl. No. 11/703,251, Aug. 28, 2015, 9 pages.

(56) **References Cited**

U.S. PATENT DOCUMENTS

- | | | | | | |
|-------------------|---------|-----------------|-------|--------------|---------|
| 5,962,970 A * | 10/1999 | Yokoi | | H01L 27/3283 | 313/505 |
| 6,069,443 A | 5/2000 | Jones et al. | | | |
| 6,107,735 A | 8/2000 | Hora | | | |
| 6,133,581 A | 10/2000 | Terao et al. | | | |
| 6,525,467 B1 | 2/2003 | Eida et al. | | | |
| 6,626,721 B1 * | 9/2003 | Van Slyke | | H01L 27/3283 | 313/504 |
| 6,876,007 B2 | 4/2005 | Yamazaki et al. | | | |
| 2002/0014837 A1 | 2/2002 | Kim et al. | | | |
| 2002/0041150 A1 | 4/2002 | Kim | | | |
| 2002/0043932 A1 | 4/2002 | Kawashima | | | |
| 2002/0057053 A1 | 5/2002 | Hitoshi | | | |
| 2003/0085403 A1 * | 5/2003 | Nagayama | | H01L 27/329 | 257/72 |

FOREIGN PATENT DOCUMENTS

- | | | |
|----|--------------|---------|
| EP | 1168448 A2 | 1/2002 |
| EP | 1191593 A2 | 3/2002 |
| EP | 1195814 A2 | 4/2002 |
| JP | H046795 A | 1/1992 |
| JP | H05275172 A | 10/1993 |
| JP | H11339970 A | 12/1999 |
| JP | 2000036391 A | 2/2000 |

* cited by examiner

FIG. 1
Related Art

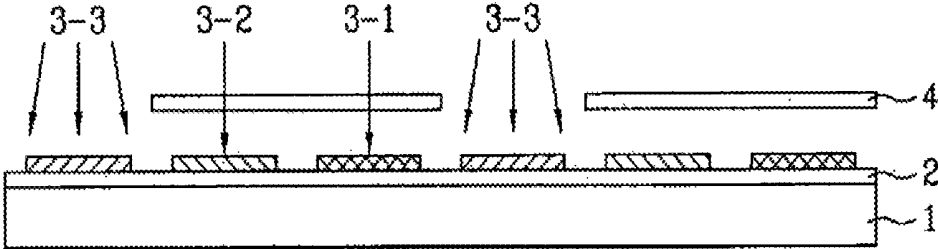

FIG. 2
Related Art

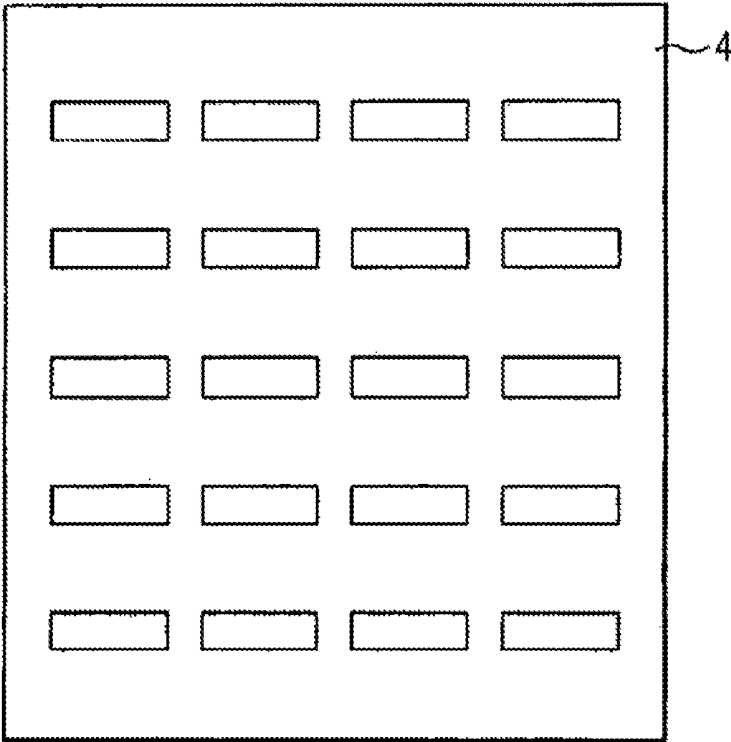

FIG. 3A

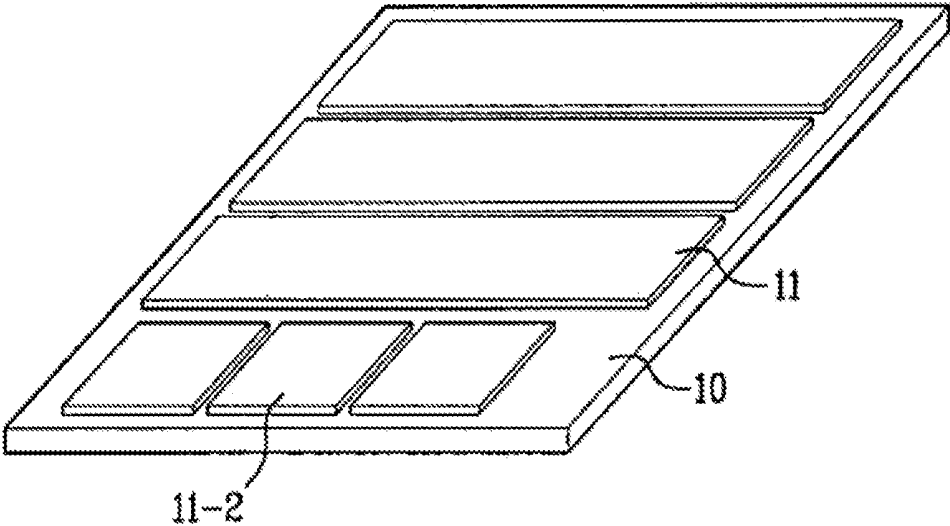

FIG. 3B

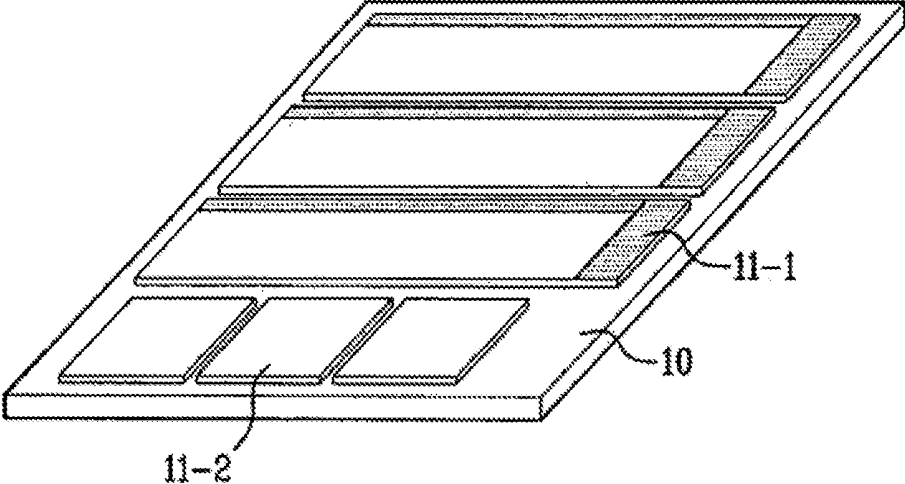

FIG. 3C

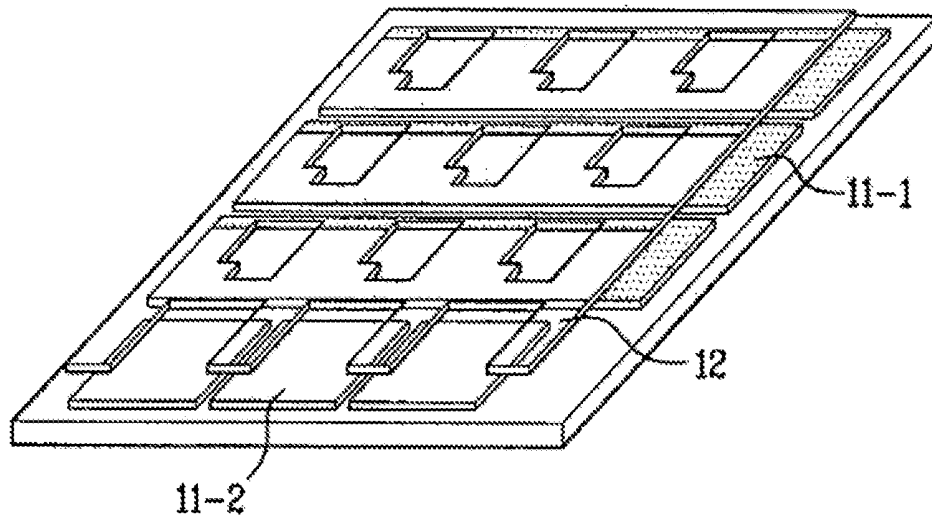

FIG. 3D

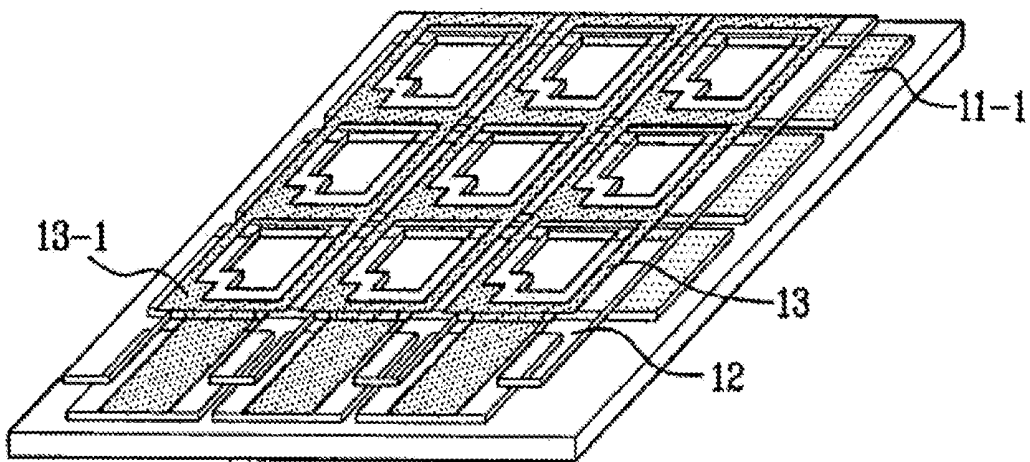

FIG. 3E

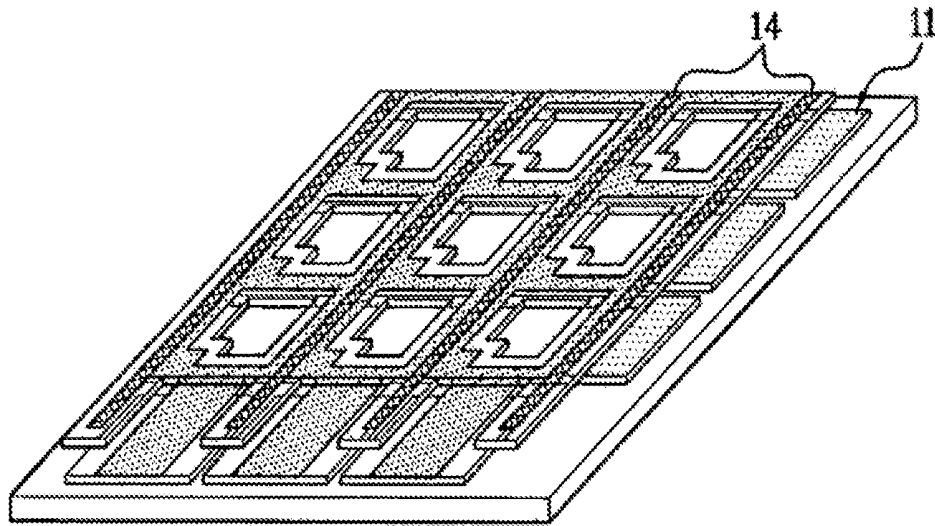

FIG. 3F

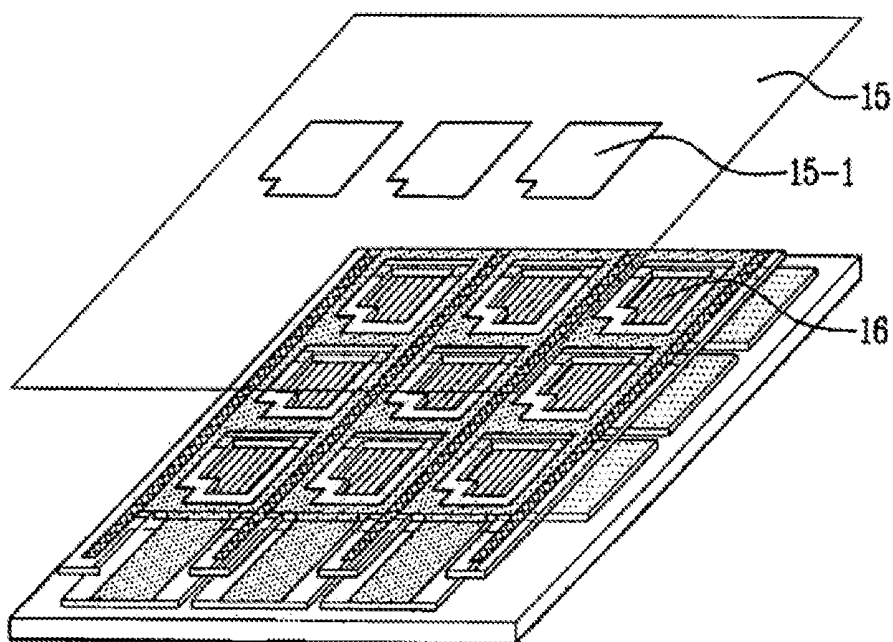

FIG. 3G

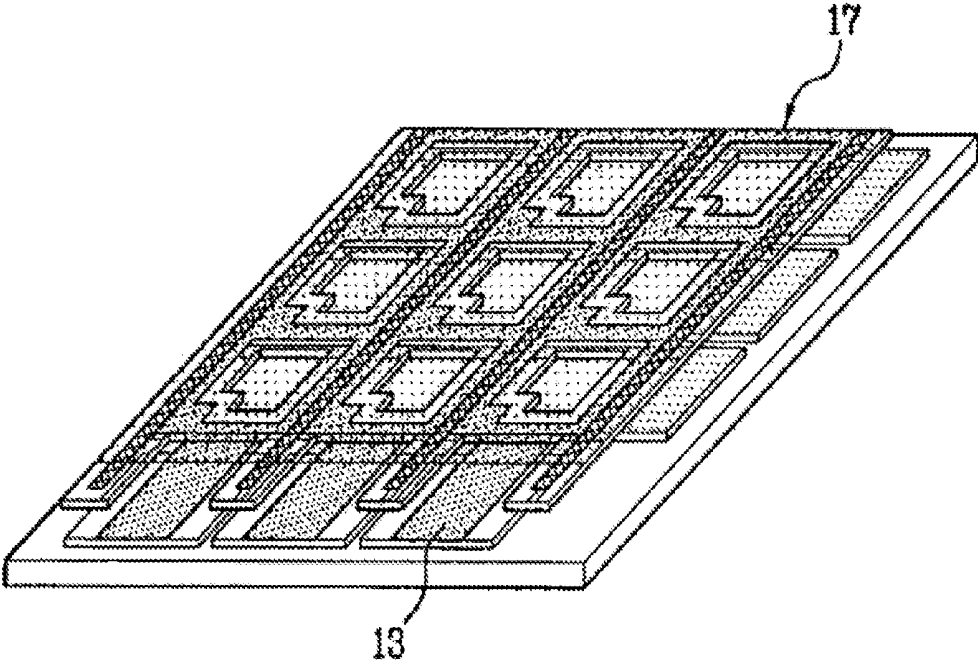

FIG. 4A

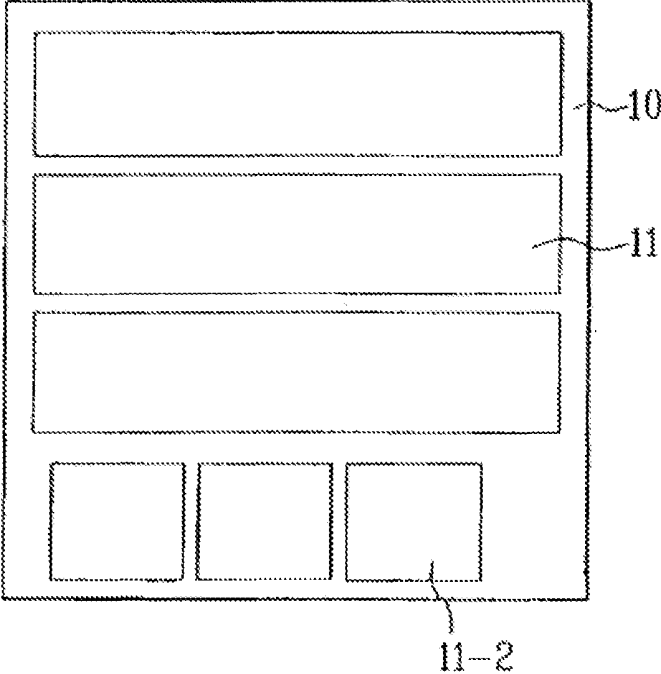

FIG. 4B

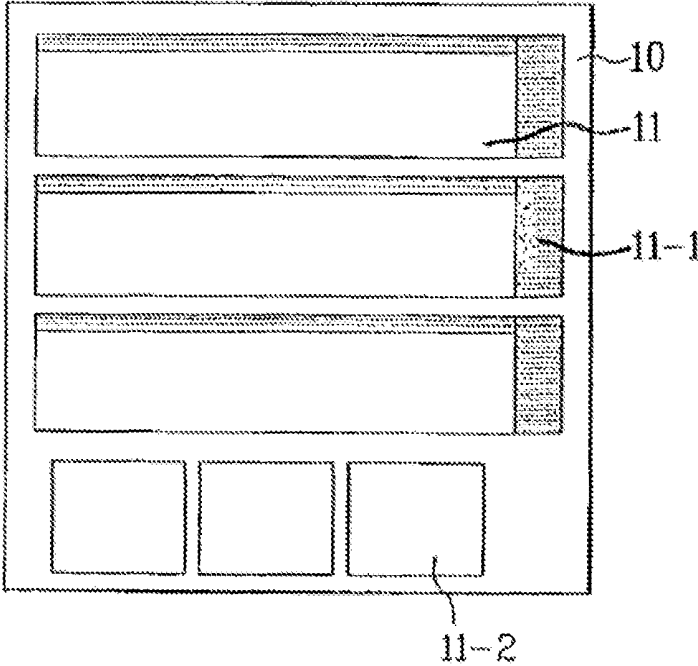

FIG. 4C

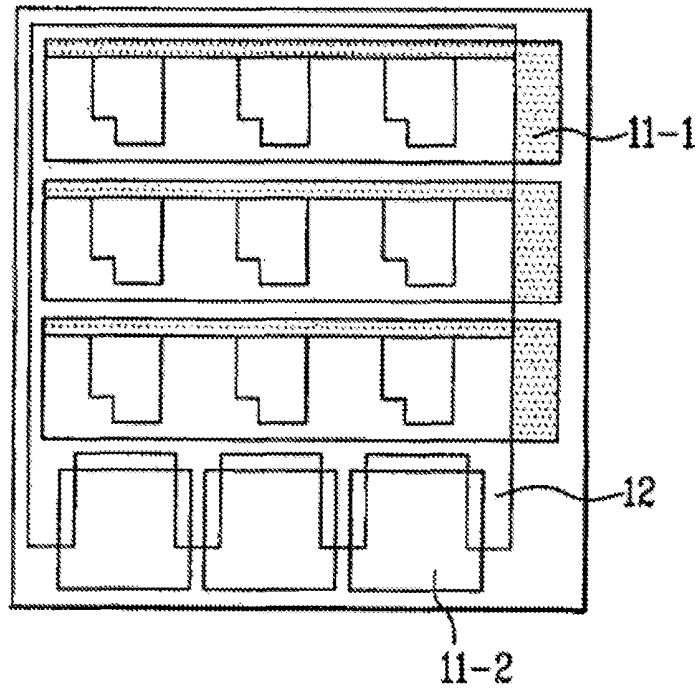

FIG. 4D

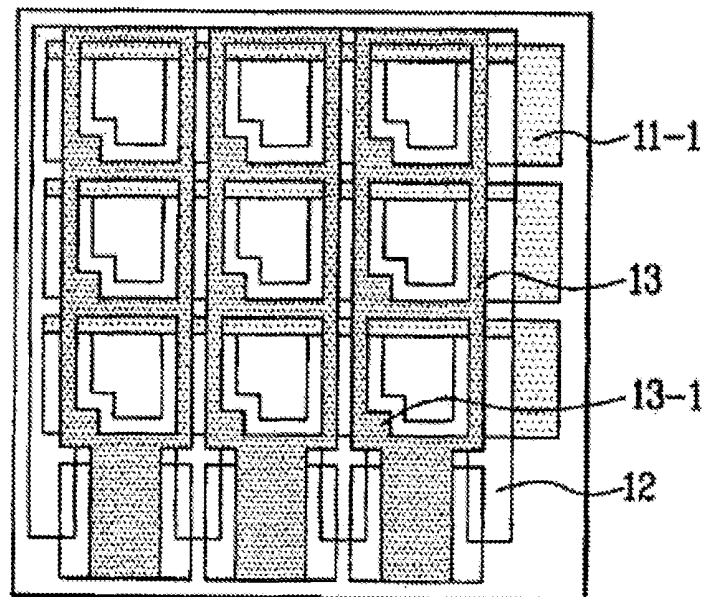

FIG. 4E

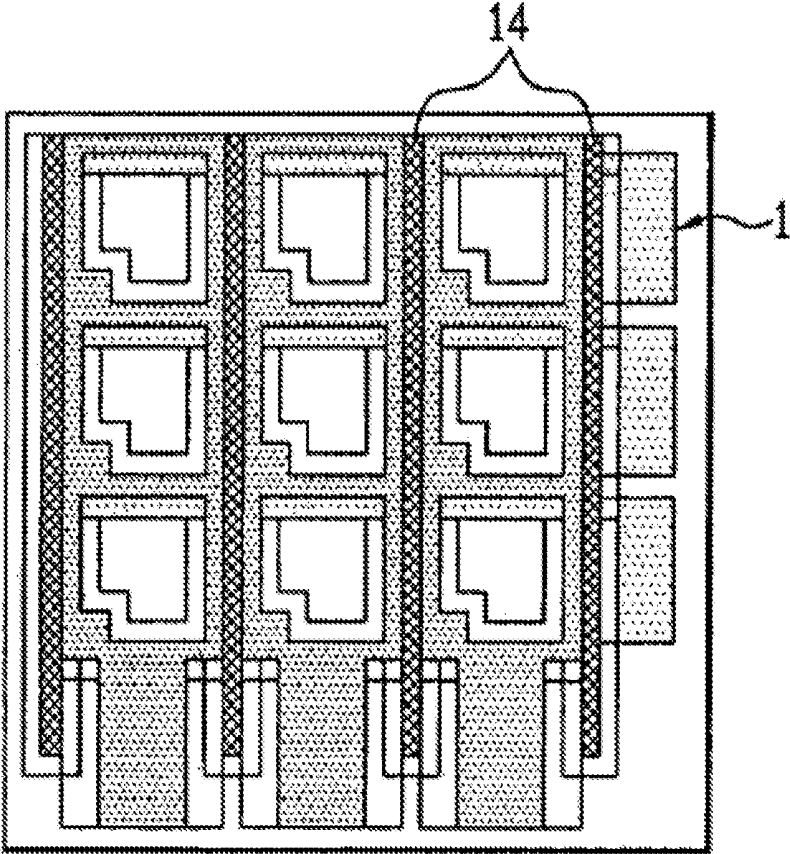

FIG. 4F

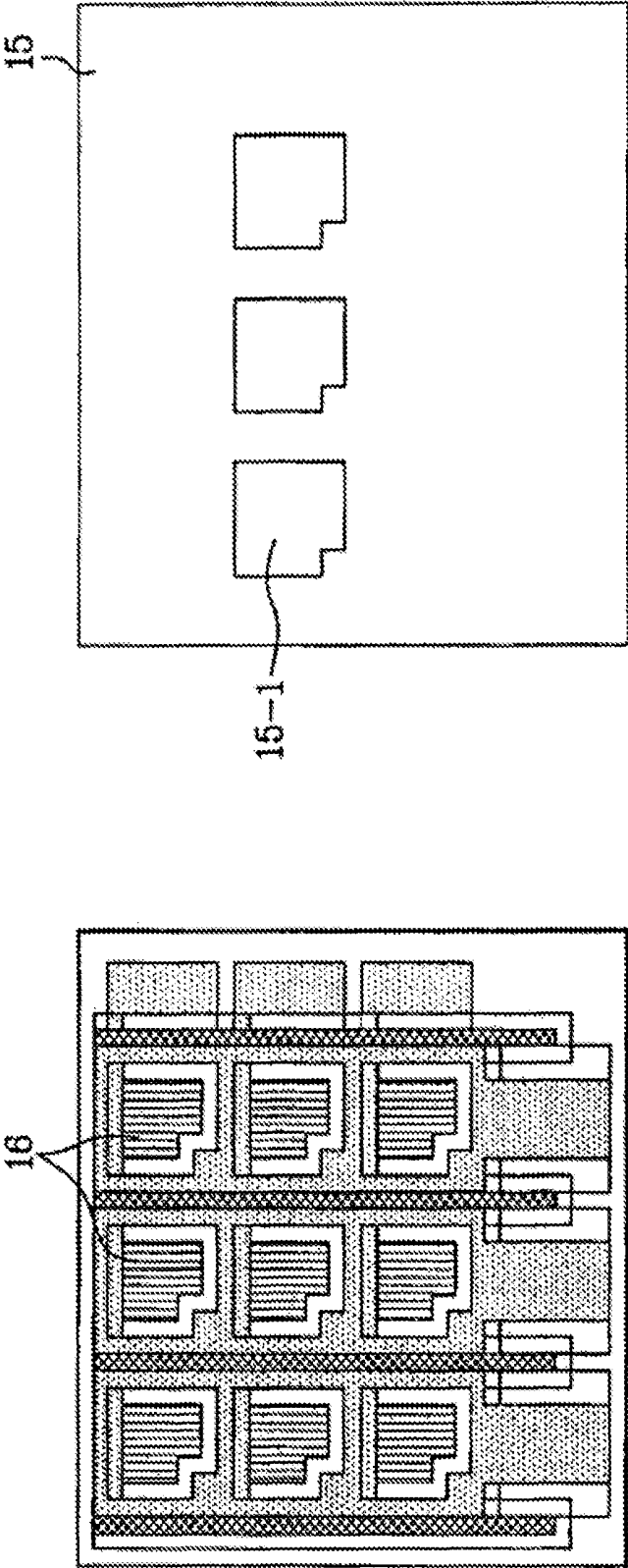

FIG. 4G

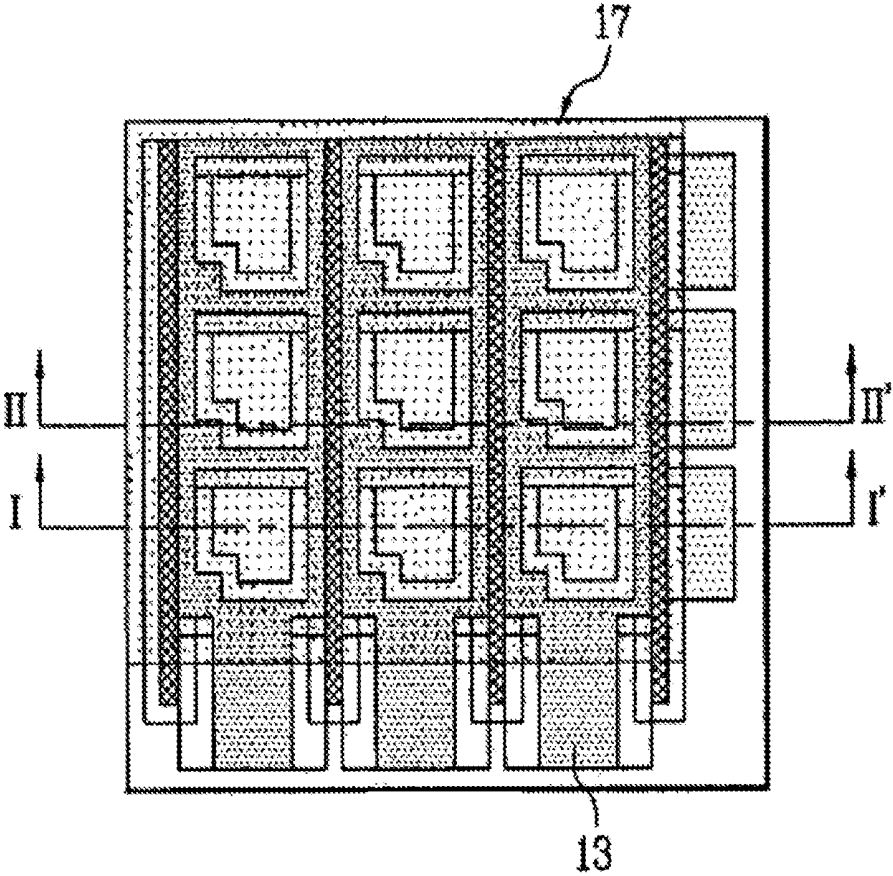

FIG. 5A

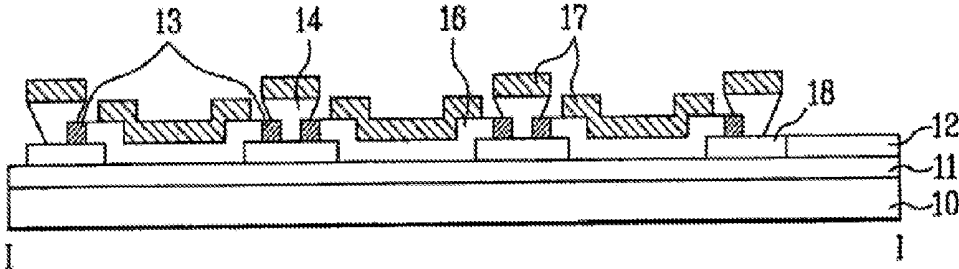
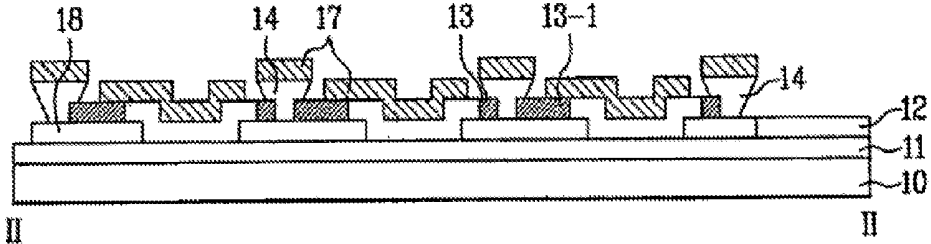

FIG. 5B



1

ORGANIC EL DISPLAY PANEL FOR REDUCING RESISTANCE OF ELECTRODE LINES

CROSS REFERENCE TO RELATED APPLICATIONS

This application is a continuation of U.S. Ser. No. 11/703, 251, filed Feb. 7, 2007, which is a continuation application of U.S. Ser. No. 10/654,896, filed Sep. 5, 2003, now U.S. Pat. No. 7,211,947, which claims priority to Korean Serial No. 10-2002-0053562, filed Sep. 5, 2002. The disclosures of the previous applications are incorporated by referenced for all purposes.

BACKGROUND

1. Field

The present invention relates to display panels, and more particularly, to an organic EL display panel, and a method for fabricating the same.

2. Background

As a size of display becomes larger, demands on flat displays that occupies smaller spaces is increasing. As one of the flat displays, the organic EL display is paid attention. The organic EL display panel has advantages in that a thickness is thin, a matrix form of addressing is available, and a driving voltage is as low as below 15V.

There are a variety of full-color display methods in fabrication of the organic EL display panel, one of which that has the best luminance efficiency is a method employing a shadow mask. FIG. 1 illustrates a section showing a related art method for fabricating an organic EL display panel, and FIG. 2 illustrates a plan view of a shadow mask employed in FIG. 1.

Referring to FIGS. 1 and 2, in the related art method for fabricating an organic EL display panel, a transparent first electrode 2 is formed on a transparent substrate 1, a barrier (not shown) is formed thereon, and red, green, blue organic EL layer 3-1, 3-2, and 3-3 are formed in succession with a shadow mask 4 as shown in FIG. 2.

Then, second electrode material is deposited on an entire surface to form a second electrode in an EL region, thereby fabricating a full color organic EL display panel. The first electrode is an anode and a second electrode is a cathode.

However, the organic EL display panel fabricated thus has waste of power, and a consequential poor efficiency, caused by a resistance of the second electrode (cathode).

In order to overcome such a poor efficiency, though it is required that the second electrode line has a thickness greater than a certain value, it is difficult to fabricate a thickness greater than the certain value by the foregoing method.

DETAILED DESCRIPTION

Accordingly, the present invention is directed to an organic EL display panel, and a method for fabricating the same that substantially obviates one or more of the problems due to limitations and disadvantages of the related art.

An object of the present invention is to provide an organic EL display panel, and a method for fabricating the same, which can reduce resistances of electrode lines, to improve efficiency.

Additional features and advantages of the invention will be set forth in the description which follows, and in part will be apparent to those having ordinary skill in the art upon

2

examination of the following or may be learned from practice of the invention. The objectives and other advantages of the invention will be realized and attained by the structure particularly pointed out in the written description and claims hereof as well as the appended drawings.

To achieve these objects and other advantages and in accordance with the purpose of the present invention, as embodied and broadly described herein, the organic EL display panel having an EL region at a cross of each of first and second electrodes, includes an electric insulating barrier formed between adjacent second electrodes for electrical insulation of the second electrodes, and a supplementary electrode around each of the EL regions, the supplementary electrode being electrically connected to one of the second electrodes.

The second electrode and the supplementary electrode are electrically connected in the vicinity of an edge of the EL region.

The supplementary electrode is formed of a material selected from Cr, Al, Au, W, Cu, Ni, and Ag.

In another aspect of the present invention, there is provided an organic EL display panel including a substrate, first electrodes on the substrate, first supplementary electrodes electrically connected to sides of the first electrodes respectively, second electrodes perpendicular to the first electrodes, an organic EL layer at every cross of the first and second electrodes, second supplementary electrodes electrically connected to the second electrodes around the EL layers respectively, and an electric insulating barrier between adjacent second electrodes for electric insulation of the second electrodes.

In further aspect of the present invention, there is provided a method for fabricating an organic EL display panel having an EL region at every cross of first and second electrodes, including the steps of forming a plurality of first electrodes at regular intervals on a transparent substrate, forming an insulating layer in regions other than the EL regions, forming second supplementary electrodes on the insulating layer, forming an electric insulating barrier between adjacent EL regions perpendicular to the first electrodes, forming an organic EL layer in each of the EL regions with a shadow mask, depositing an electrode material on an entire surface inclusive of the organic EL layer, to form a plurality of second electrodes electrically connected to the second supplementary electrodes, and forming a protection film on an entire surface inclusive of the second electrodes.

The step of forming a plurality of first electrodes further includes the step of forming first supplementary electrodes electrically connected to sides of the first electrodes.

The second supplementary electrodes includes projected parts in the vicinity of edges of the EL regions so as to be in contact with the second electrodes, respectively.

It is to be understood that both the foregoing description and the following detailed description of the present invention are exemplary and explanatory and are intended to provide further explanation of the invention claimed.

BRIEF DESCRIPTION OF THE DRAWINGS

The accompanying drawings, which are included to provide a further understanding of the invention and are incorporated in and constitute a part of this application, illustrate embodiment(s) of the invention and together with the description serve to explain the principle of the invention. In the drawings;

FIG. 1 illustrates a section showing a related art method for fabricating an organic EL display panel;

FIG. 2 illustrates a plan view of a shadow mask employed in FIG. 1;

FIGS. 3A~3G illustrate perspective views each showing the steps of a method for fabricating an organic EL display panel in accordance with a preferred embodiment of the present invention;

FIGS. 4A~4G illustrate plan views each showing the steps of a method for fabricating an organic EL display panel in accordance with a preferred embodiment of the present invention;

FIG. 5A illustrates a section across a line I-I in FIG. 4G; and

FIG. 5B illustrates a section across a line II-II in FIG. 4G.

DETAILED DESCRIPTION

Reference will now be made in detail to the preferred embodiments of the present invention, examples of which are illustrated in the accompanying drawings. FIGS. 3A~3G illustrate perspective views each showing the steps of a method for fabricating an organic EL display panel in accordance with a preferred embodiment of the present invention, and FIGS. 4A~4G illustrate plan views each showing the steps of a method for fabricating an organic EL display panel in accordance with a preferred embodiment of the present invention.

Referring to FIGS. 3A and 4A, first electrodes **11** and pads **11-2** of second electrodes are formed of transparent material on a transparent substrate **10**.

Then, referring to FIGS. 3B and 4B, for reducing resistance of the first electrodes **11**, a first supplementary electrode **11-1** is formed such that a part of the first supplementary electrode **11-1** is overlapped with an edge of each of the first electrodes **11**. The first supplementary electrode **11-1** is formed of a metal that has a resistance relatively lower than ITO of the first electrode **11**, such as Cr, Al, Cu, W, Au, Ni, and Ag.

Referring to FIGS. 3C and 4C, an insulating layer **12** is formed in region except an EL region. The insulating layer **12** may be formed of any organic or inorganic material, as far as the material is insulator.

Referring to FIGS. 3D and 4D, a second supplementary electrodes **13** are formed on the insulating layer **12**. Each of the second supplementary electrodes **13** has a projected part **13-1** in the vicinity of the edge of the EL region so as to be in contact with each of the second electrodes, electrically. The second supplementary electrode **13** to be in contact with each of the second electrodes is formed of a metal having a resistance lower than the second electrodes relatively, such as Cr, Al, Cu, W, Au, Ni, and Ag.

Referring to FIGS. 3E and 4E, a buffer layer (not shown) is formed between adjacent EL regions in a direction perpendicular to the first electrode **11**, and an electric insulating barrier on each of the buffer layers.

Referring to FIGS. 3F and 4F, an organic EL layer **16** is formed in each of the EL regions with a shadow mask **15** having a plurality of via holes **15-1**. The via holes **15-1** in the shadow mask **15** are in conformity with the EL regions.

Then, referring to FIGS. 3G and 4G, an electrode material is deposited on an entire surface inclusive of the organic EL layer, to form a plurality of second electrodes **17** electrically connected to the second supplementary electrodes **13**, respectively.

Though not shown, a protection film is formed on an entire surface inclusive of the second electrode **17**, and an

encapsulation is carried out, to finish fabrication of the organic EL display panel. The first electrode is an anode and the second electrode is cathode.

FIG. 5A illustrates a section across a line I-I in FIG. 4G, and FIG. 5B illustrates a section across a line II-II in FIG. 4G.

Referring to FIGS. 5A and 5B, the organic EL display panel of the present invention has an EL region at every cross of the first electrodes **11** and the second electrodes **17**.

Moreover, the electric insulating barrier **14**, formed on each of the buffer layers **18** between adjacent EL regions, insulates the second electrodes **17** from each other, electrically.

Furthermore, the second supplementary electrode **13**, formed around each of the EL regions, is connected to each of the second electrodes **17**, electrically. Each of the second electrodes **17** is connected to one of the projected parts **13-1** of the second supplementary electrodes **13**.

Thus, since the second supplementary electrode can reduce a resistance of the second electrode (cathode), an efficiency of the organic EL display can be improved, and a power required for operating the organic EL display can be reduced, to reduce waste of power.

It will be apparent to those skilled in the art that various modifications and variations can be made in the present invention without departing from the spirit or scope of the invention. Thus, it is intended that the present invention cover the modifications and variations of this invention provided they come within the scope of the appended claims and their equivalents.

What is claimed is:

1. An organic EL display comprising:

- a substrate having an EL region;
- an anode on the EL region of the substrate;
- a supplementary electrode coupled to a portion of the anode;
- an insulating layer provided in regions other than the EL region, the insulating layer being contiguous and vertically spaced away from the substrate;
- an organic EL layer on the EL region;
- a cathode on the organic EL layer; and
- a plurality of pads on the substrate at a location proximate to the anode, wherein:
 - the insulating layer includes a first projection part and a second projection part, the first projection part projecting between adjacent ones of the pads, and the second projection part extending from a first side of the EL region.

2. The organic EL display of claim 1, wherein a lower surface of the supplementary electrode is coupled to an upper surface of the anode.

3. The organic EL display of claim 1, wherein the supplementary electrode has resistance lower than that of the anode.

4. The organic EL display of claim 1, further comprising a second supplementary electrode on the insulating layer, wherein the supplementary electrode is a first supplementary electrode.

5. The organic EL display of claim 4, wherein the second supplementary electrode includes a first supplementary projection part and a second supplementary projection part.

6. The organic EL display of claim 5, wherein the first supplementary projection part is between the first projection part of the insulating layer, and the second supplementary projection part is on the second projection part of the insulating layer at a corner area of the EL region.

5

7. The organic EL display of claim 1, wherein the anode includes at least indium tin oxide (ITO), and the supplementary electrode includes at least Ag.

8. The organic EL display of claim 1, wherein the second projection part is at a corner area of the EL region.

9. The organic EL display of claim 1, wherein the second projection part extends from the first side of the EL region toward an interior area of the EL region.

10. The organic EL display of claim 1, wherein the second projection part extends from a second side of the EL region toward an interior area of the EL region.

11. An organic EL display comprising:

a substrate having an EL region;
a first electrode on the EL region of the substrate;
an insulating layer provided in regions other than the EL region, the insulating layer being contiguous and vertically spaced away from the substrate;

an organic EL layer on the EL region;
a second electrode on the organic EL layer;
a plurality of pads on the substrate at a location proximate to the first electrode; and

a supplementary electrode coupled to an end portion of the first electrode or the second electrode, wherein:

the insulating layer includes a first projection part and a second projection part, the first projection part projecting between adjacent ones of the pads, and the second projection part extending from a first side of the EL region.

12. An organic EL display comprising:

a substrate having an EL region;
a first electrode on the EL region of the substrate;
a supplementary electrode coupled to a portion of the first electrode;

an insulating layer at regions of the substrate other than the EL region, the insulating layer being contiguous and vertically spaced away from the substrate;

an organic EL layer on the EL region;
a second electrode on the organic EL layer; and

6

a plurality of pads on the substrate at a location proximate to the first electrode, wherein:

the insulating layer includes a first projection part and a second projection part, the first projection part projecting between adjacent ones of the pads, and the second projection part extending from a first side of the EL region.

13. The organic EL display of claim 12, wherein one of the first or second electrode is a cathode and the other one of the first or second electrode is an anode, and wherein the cathode includes at least Ag.

14. The organic EL display of claim 13, wherein a protection layer is provided over the cathode.

15. The organic EL display of claim 12, wherein an insulating barrier is provided between adjacent light emitting elements.

16. The organic EL display of claim 12, wherein the organic EL display is encapsulated.

17. The organic EL display of claim 12, wherein the supplementary electrode has a smaller dimension than the first electrode.

18. The organic EL display of claim 12, further comprising a second supplementary electrode coupled to a portion of the second electrode, wherein the supplementary electrode is a first supplementary electrode.

19. The organic EL display of claim 18, wherein the second supplementary electrode includes a first supplementary projection part and a second supplementary projection part, the first supplementary projection part being between the first projection part of the insulating layer, and the second supplementary projection part being on the second projection part of the insulating layer at a corner area of the EL region.

20. The organic EL display of claim 12, wherein the second projection part is at a corner area of the EL region and extends from the first side of the EL region toward an interior area of the EL region and extends from a second side of the EL region toward the interior area of the EL region.

* * * * *

专利名称(译)	有机EL显示面板，用于降低电极线的电阻		
公开(公告)号	US9723687	公开(公告)日	2017-08-01
申请号	US14/959624	申请日	2015-12-04
[标]申请(专利权)人(译)	微软技术许可有限责任公司		
申请(专利权)人(译)	微软技术Licensing，LLC公司		
当前申请(专利权)人(译)	微软技术Licensing，LLC公司		
[标]发明人	KIM CHANG NAM		
发明人	KIM, CHANG NAM		
IPC分类号	H01L51/52 H05B33/26 H05B33/10 H05B33/06 H05B33/14 H01L27/32 H01L51/50 H05B33/22		
CPC分类号	H05B33/26 H01L51/5206 H01L51/5212 H01L51/5221 H05B33/06 H05B33/10 H05B33/14 H01L27/3211 H01L27/3281		
审查员(译)	MAI，ANH		
助理审查员(译)	LEE纳撒尼尔		
优先权	1020020053562 2002-09-05 KR 10/654896 2007-05-01 US		
其他公开文献	US20160120006A1		
外部链接	Espacenet USPTO		

摘要(译)

制造在第一和第二电极的每个交叉处具有EL区域的有机EL显示板的方法，包括在透明基板上以规则间隔形成多个第一电极，在除EL区域之外的区域中形成绝缘的步骤，在绝缘层上形成第二辅助电极，在垂直于第一电极的相邻EL区域之间形成电绝缘屏障，在每个EL区域中用荫罩形成有机EL层，在整个表面上沉积电极材料在有机EL层中，形成多个第二电极，并在包括第二电极的整个表面上形成保护膜。

